

## Design and Manufacturing of 3 Axis Portable Drilling Machine

Prof. A.D.Halwe<sup>1</sup>, Siddheshwar Chatter<sup>2</sup>, Vipul Chaudhari<sup>3</sup>, Darshan Chavan<sup>4</sup>  
Suraj Biradar<sup>5</sup>

<sup>1</sup>(Asst. Prof. Department of Mechanical Engineering JSPM NTC, PUNE)  
<sup>2,3,4,5</sup>(Student of Mechanical Department 1<sup>st</sup> shift, JSPM NTC, PUNE.)

**Abstract:** Lift is a simple mechanical device used to raise element or object from ground level to a certain height to perform a specific work with maximum load and minimum efforts. This project describes the design and fabrication of scissor lift which will be operated on DC motors for drilling application. . In the present market the fix drilling machine are available & in most of the industries the drilling is done manually. It requires man power & more skilled workers. For drilling at different position we need either a manual process or more drilling machine. The former one consumes lot of time the later is quite costlier. For portable drilling we net to move the spindle in all three directions. For this we used lead screw, scissor mechanism etc. In our machine we have made lead screw arrangement, scissor mechanism, motors etc. Thus based on the functional and economical aspects we have fabricated a unique machine.

**Keywords:** lift, portable drilling machine, spindle, scissor mechanism,

### I. Introduction

A scissor lift or mechanism is a device used to extend or position a platform by mechanical means. The term “scissor” comes from the mechanic which has folding supports in criss cross “X” pattern, which is known as Pantograph. The drilling machine is one of the most important machine tool. In a drilling machine holes may be drilled quickly. The holes is generated by the rotating edge of a cutting tool known as the drill which exerts large force on the work clamped on the table. As the machine exerts vertical pressure to originate a hole it is also called as a “Drill Press”. The holes are drilled on number of work pieces with the same accuracy, so as to make them interchangeable. This machine has spindles driven by a single motor and spindle is fed in to the work piece simultaneously. Feeding motions are obtained by the mechanism of lead screw by moving drill head towards work piece. The centre distance between the spindles can be adjusted in any position as required by the different jobs by sliding drilling head on lead screw. we designed the drilling head according to application that is according to diameter of steady pin hole and thrust force (Reaction) coming from pump while operating.

### II. Problem Statement

In the industries the drilling operation is most likely operation. In each of manufacturing process the drilling operation s very important. But now in the most of industries the drilling is done on the drilling machine which is place at a location. This is the main drawback in the large application where we can't drill by such machines.

To overcome such problem we are developing the portable drilling machine

### III. Objective

There are few objectives of the project.

- Reduce time required for drill steady pin hole on boring machine.
- Avoid material handling by special purpose cranes.
- To reduce man power.
- Design of a versatile portable machine which can also use for drilling operation on group 1 to 5 pumps.
- To increase productivity.

### IV. Components of system

- Lead screw
- DC motor
- Scissor mechanism
- Base
- Controls

### **A. Lead screw**

In our machine we are using total 3 lead screws. One of them is for drilling operation. Other is for movement of top slider in X direction of diameter 35 mm. And third is to lift the scissor upward.

Linear motion can be achieved by means other than through the use of lead screws. Chain and cable drives along with belt and pulley drives do not require pumps and support hardware as do hydraulic and pneumatic systems. They can carry very small to very heavy loads at great speeds when needed. However, these systems are not as accurate or as repeatable as lead screws, and they generally require a greater number of components, are more complicated to install, and require more maintenance during operation. In addition, recalculating or running chains, cables, or belts can be a safety hazard. Lead screw drive systems are selected for linear motion over the other possible choices when the requirements are for:

- Accuracy in Positioning
- Load Capacity
- Repeatability

Lead screw assemblies usually consist of the screw and nut assembly supported in bearings and driven with a motor. This sub-assembly is attached to the load to be moved. Because of their compactness and simplicity, lead screw assemblies lend themselves to virtually any kind of drive mechanism. Since the drive method can be directly connected to the lead screw, the motion is much easier to control precisely.

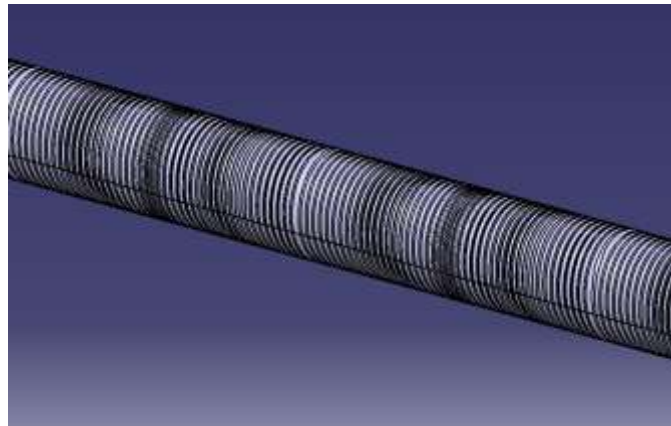

**Figure 1 Lead Screw**

### **B. DC Motor**

Every DC motor has six basic parts -axle, rotor (armature), stator, commutator, field magnet(s), and brushes. In most common DC motors (and all that BEAMs will see), the external magnetic field is produced by high-strength permanent magnets. The stator is the stationary part of the motor -- this includes the motor casing, as well as two or more permanent magnet pole pieces. The rotor (together with the axle and attached commutator) rotates with respect to the stator. The rotor consists of windings (generally on a core), the windings being electrically connected to the commutator with the rotor inside the stator (field) magnets



**Figure 2DC Motor**

#### **Specifications**

Voltage=12v,

Amp=2, T=3kg, Rpm=30

### C. Scissor mechanism

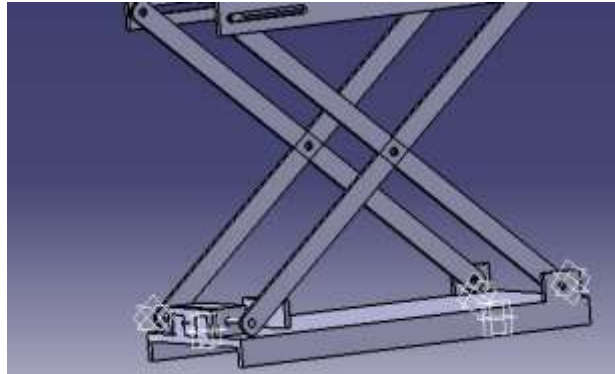

Figure 3 Scissor Mechanism

Extension is achieved by applying pressure to the outside of a set of supports located at one end of the mechanism, elongating the crossing pattern. This can be achieved through hydraulic, pneumatic, mechanical or simply muscular means.

It may require no power to return to its original position, but simply a release of the original pressure. Also used in kinematic of mechanisms

### D. Base

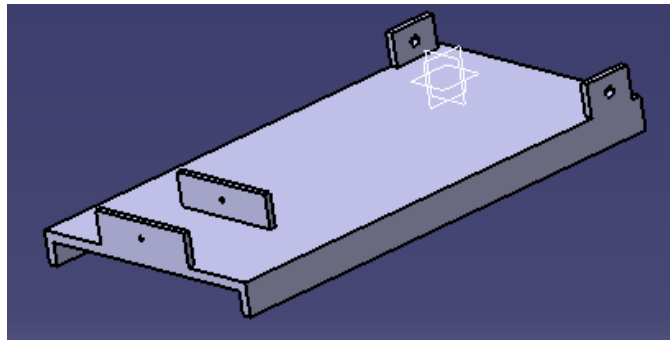

Figure 4 Base

Base is the rigid part of the machine total assembly is assembling on the base

## V. Design and Calculation

### 1. Cutting Speed (v):-

It's the peripheral speed of the drill. The cutting speed depends upon the properties of the material being drilled, drill material, drill diameter, rate of speed, coolant used etc...

$$v = \pi * D * N \text{ where}$$

D = dia of the drill in m

N = Speed of rotation in rpm

### 2. Feed Rate (f):-

It's the movement of drill along the axis (rpm)

### 3. Depth of Cut (d):-

The distance from the machined surface to the drill axis.

$$d = D / 2$$

As the depth of hole increases, the chip ejection becomes more difficult and the fresh cutting fluid is not able to cutting zone. Hence for machining the lengthy hole special type of drill called 'gun drill' is used.

### 4. Material Removal Rate:-

It's the volume of material removed by the drill per unit time

$$MRR = (\pi D^2 / 4) * f * N \text{ mm}^3 / \text{min}$$

### 5. Machining Time (T):-

It depends upon the length (l) of the hole to be drilled, to the Speed (N) and feed (f) of the drill

$$t = L / f N \text{ min}$$

## VI. CAD Model

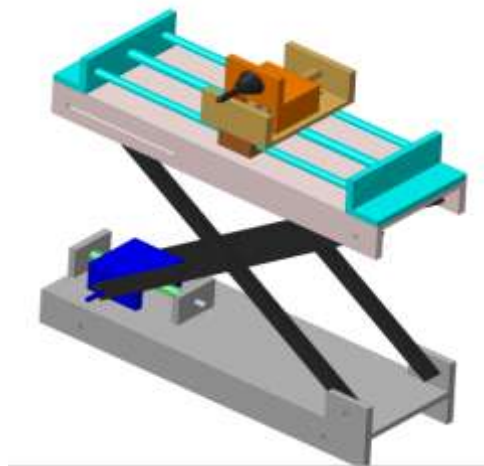

**Figure 5 CAD Model**

## VII. Advantages

The following are the advantages of this machine:-

- Minimum number of components, so the maintenance of the machine is easier.
- No skilled operators are required.
- Enables high production rate.
- The machine is less expensive.
- Consumes less floor area.
- Noiseless and smooth in operation.
- Breakage of tool is avoided by slipping of cone.
- The machine is auto reversible.

## VIII. Conclusion

We successfully designed the portable drilling machine for the drilling operation in industries. It reduces the time required to perform the application. In this project we are designing and fabricating of a 3-DOF manipulator has been successfully completed. We prepare a prototype to replicate the proposed system. And perform the operation for which we designed the machine. Drill at different position in single attempt.

## References

- [1]. Shinde Nikhil, Vishwakarma Prem, Sanjay Kumar, Godse Rahul, P.A. Patil, "Design & Development of Twin Drill Head Machine and Drilling Depth Control", International Journal of Innovative Research in Science, Engineering and Technology (An ISO 3297: 2007 Certified Organization) Vol. 4, Issue 5, May 2015
- [2]. Pravin A. Desai, Vishal V. Jadhav, "DESIGN OF MULTI SPINDLE DRILLINGMACHINE", International Journal of Design and Manufacturing Technology (IJDMT) Volume 8, Issue 2, May-August, pp. 01–22, Article ID: IJDMT\_08\_02\_001
- [3]. R.Anandhan, P.Gunasekaran, D.Sreenevasan, D.Rajamaruthu, "Design and Fabrication of Angular Drilling Machine", International Journal of Innovative Research in Science, Engineering and Technology (An ISO 3297: 2007 Certified Organization) Vol. 5, Special Issue 8, May 2016,
- [4]. Osamu Horiuchi et al, (2013) Bending of Drill and Radial Forces in Micro Drilling, Advanced Materials Research, 797, 642.
- [5]. Ajay Kumar Singh, Nishant Moona, "Design of a Universal Micro Radial Drilling Machine", IJSTE - International Journal of Science Technology & Engineering | Volume 2 | Issue 09 | March 2016 ISSN (online): 2349-784X.
- [6]. Suman Chatterjee, Siba Sankar Mahapatra, Kumar Abhishek, (2016) Simulation and optimization of machining parameters in drilling of titanium alloys
- [7]. A.S.Udgave, Prof.V.J.Khot, "Design & development of multi spindle drilling head (msdh)", IOSR Journal of Mechanical and Civil Engineering (IOSR-JMCE) ISSN: 2278-1684, PP: 60-69
- [8]. Yi Xin Yang et al, (2010) Advanced Materials Research 126-128, 779.
- [9]. Tapas Kumar (2013) Experimental investigation of micro drilling operation of printed circuit board. B.Tech Thesis.
- [10]. Dilip Kumar Bagal, Experimental investigation and modelling micro drilling operation of aerospace material.
- [11]. I. Garitaonandia, M.H. Fernandes, J.M. Hernandez-Vazquez, J.A. Ealo, Prediction of dynamic behaviour for different configurations in a drilling-milling machine based on substructuring analysis.